

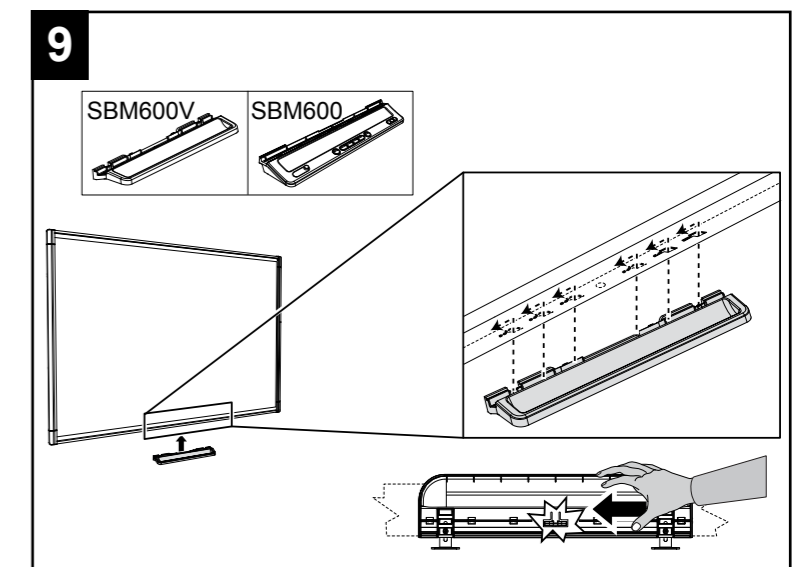

# SBM600/SBM600V

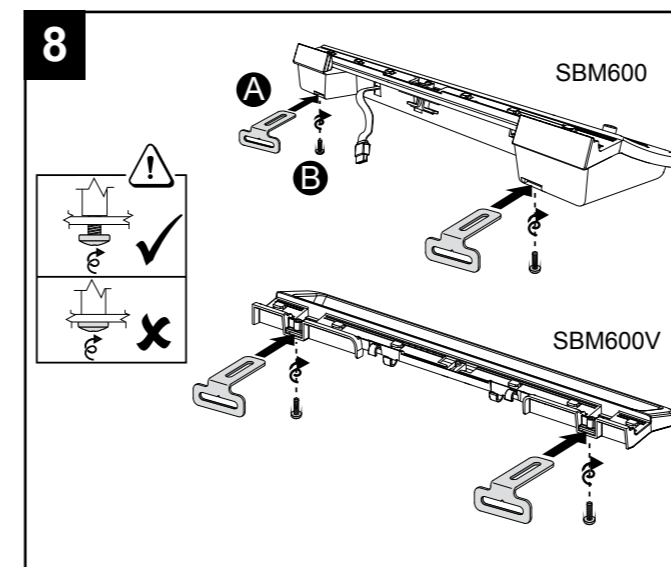

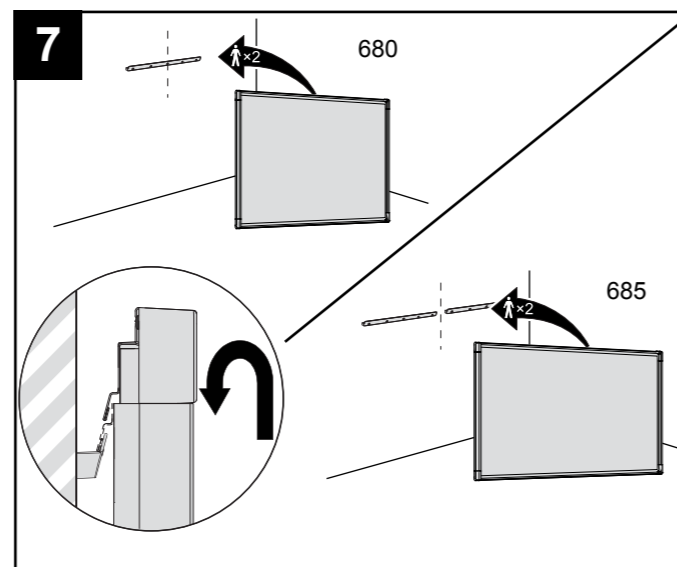
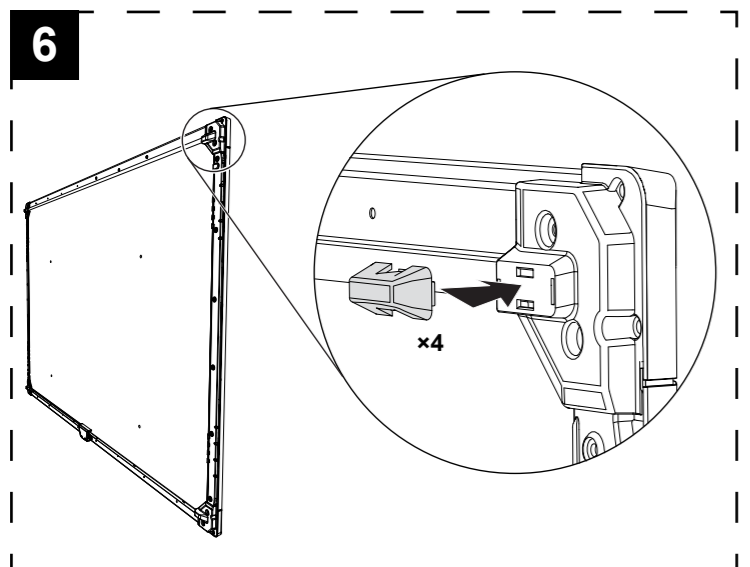
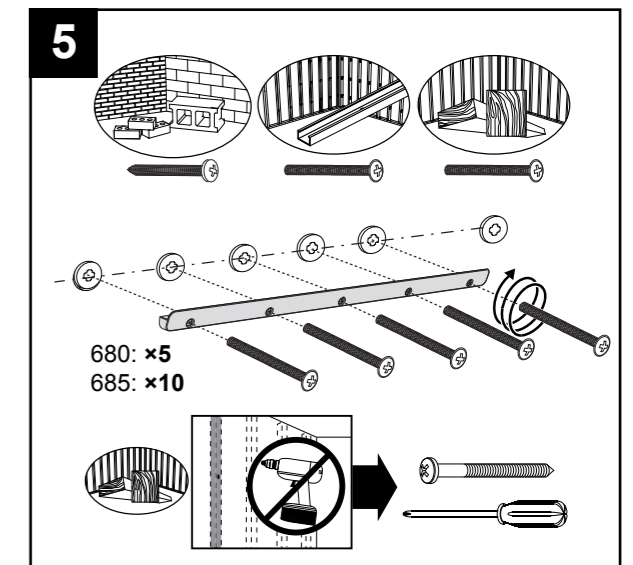
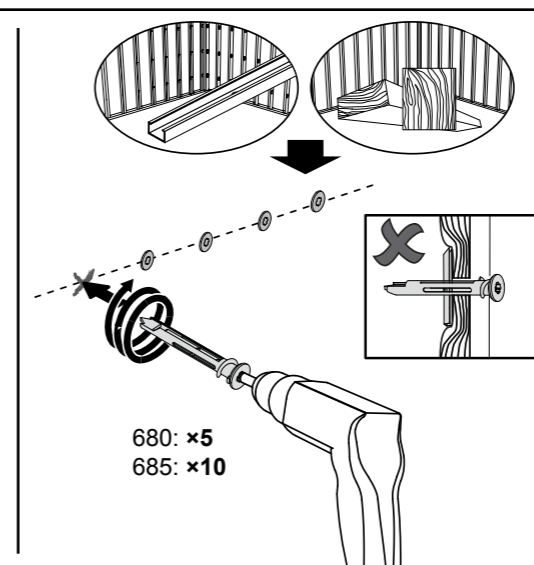
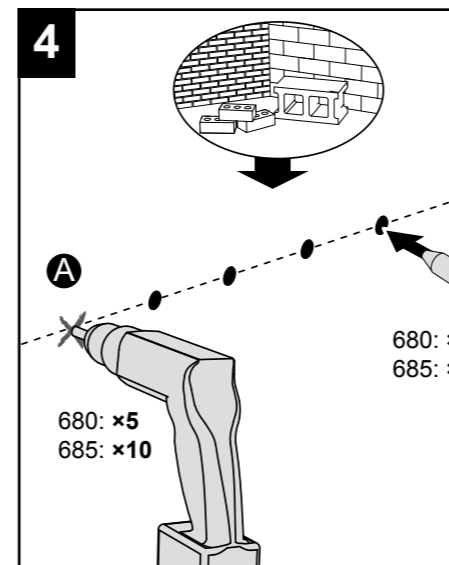
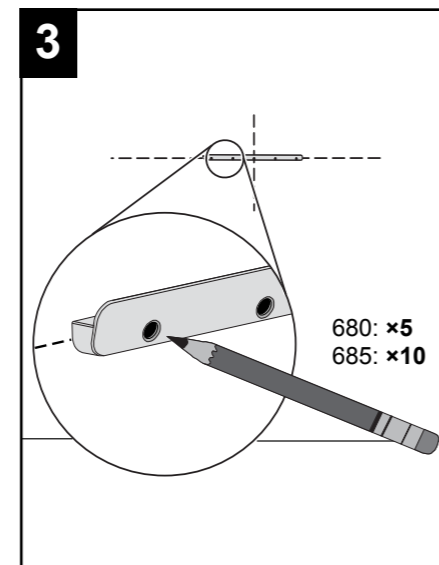
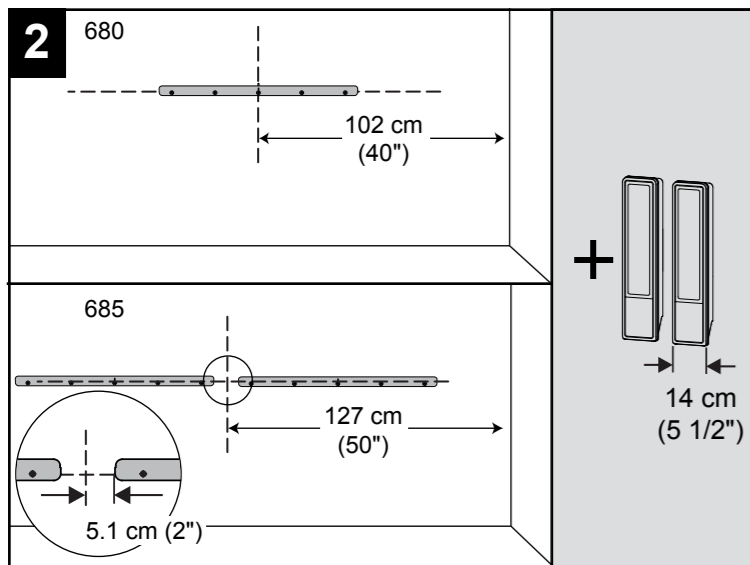
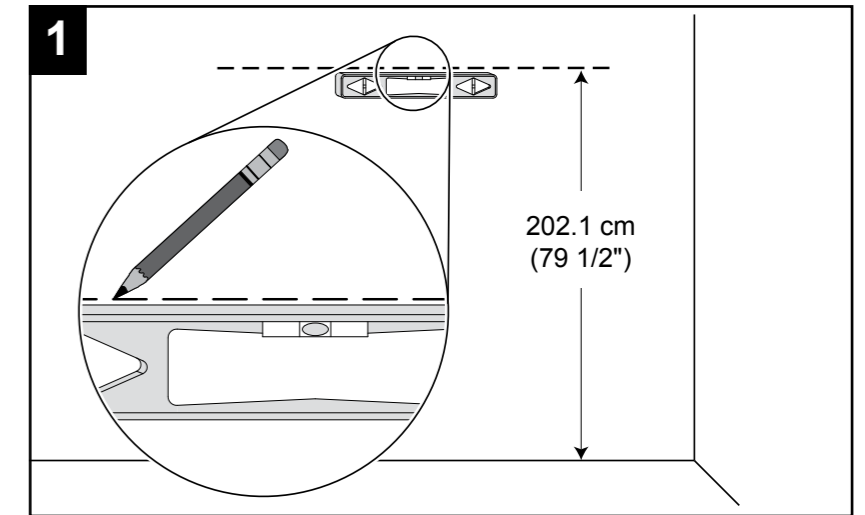
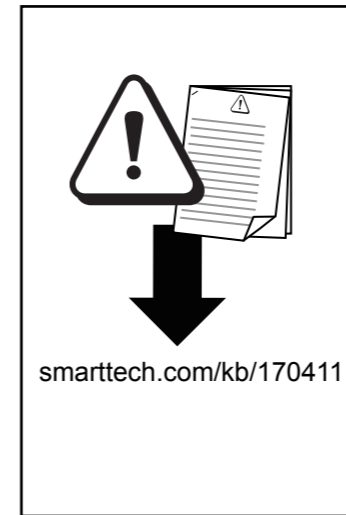
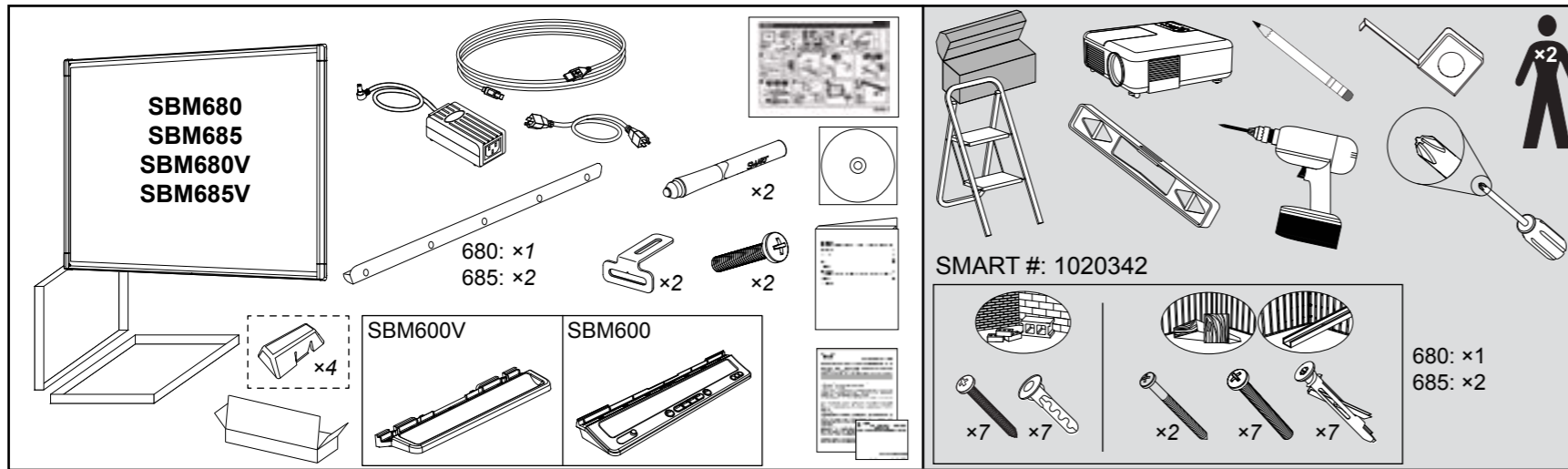
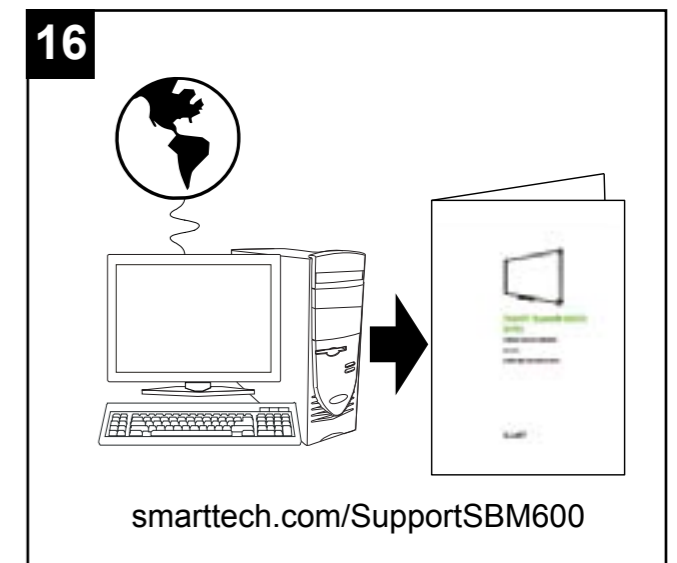
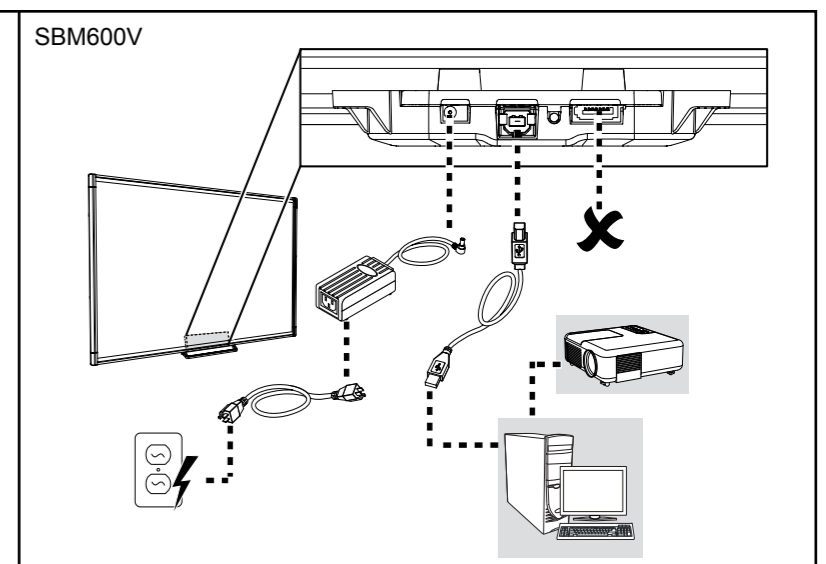
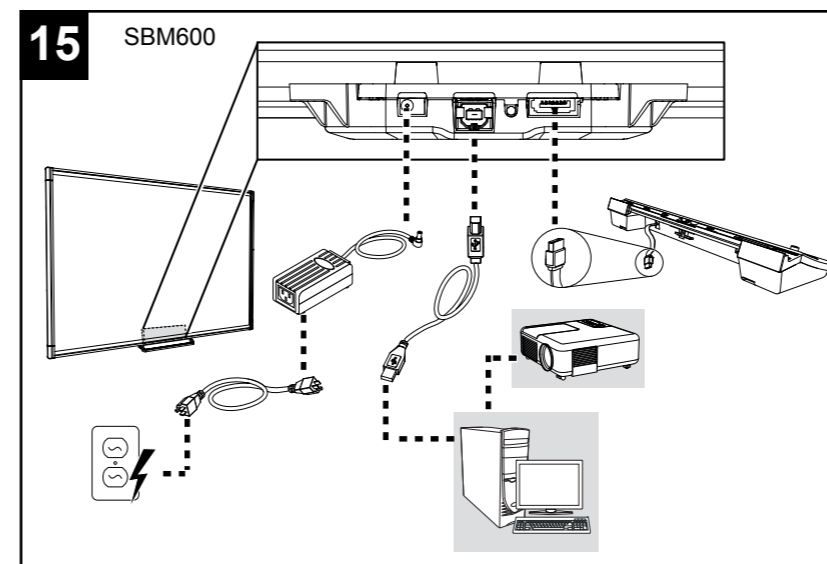
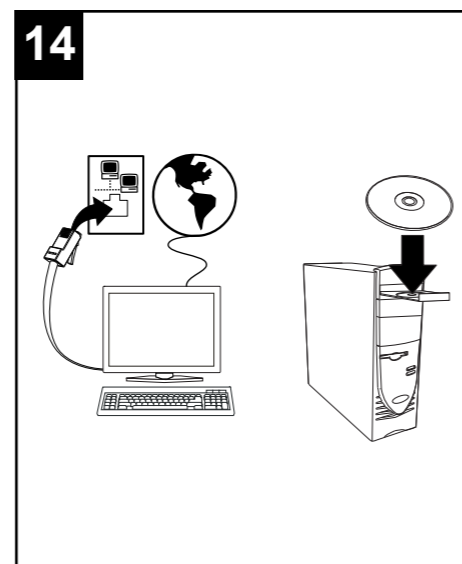
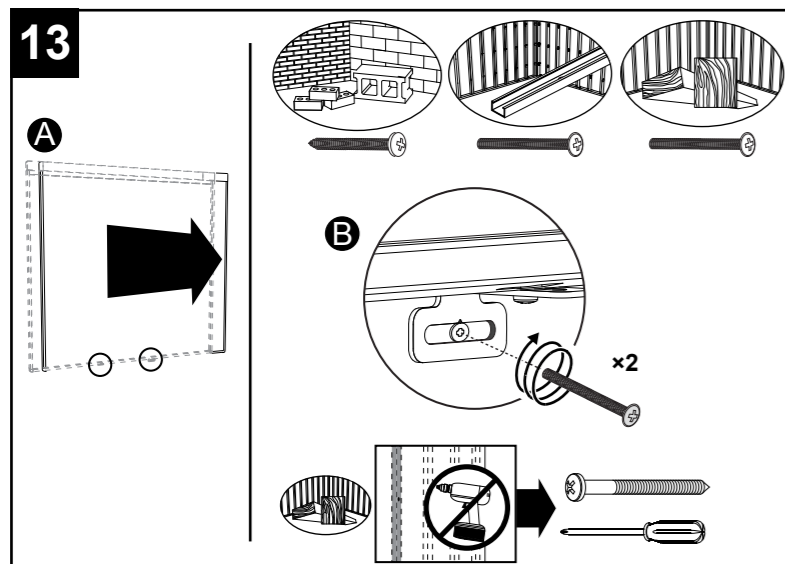
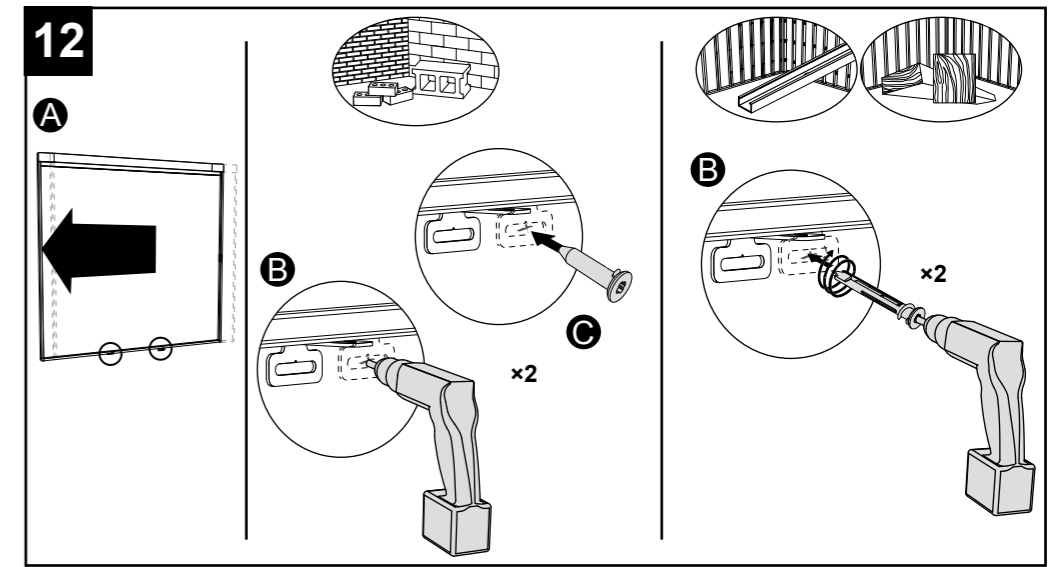
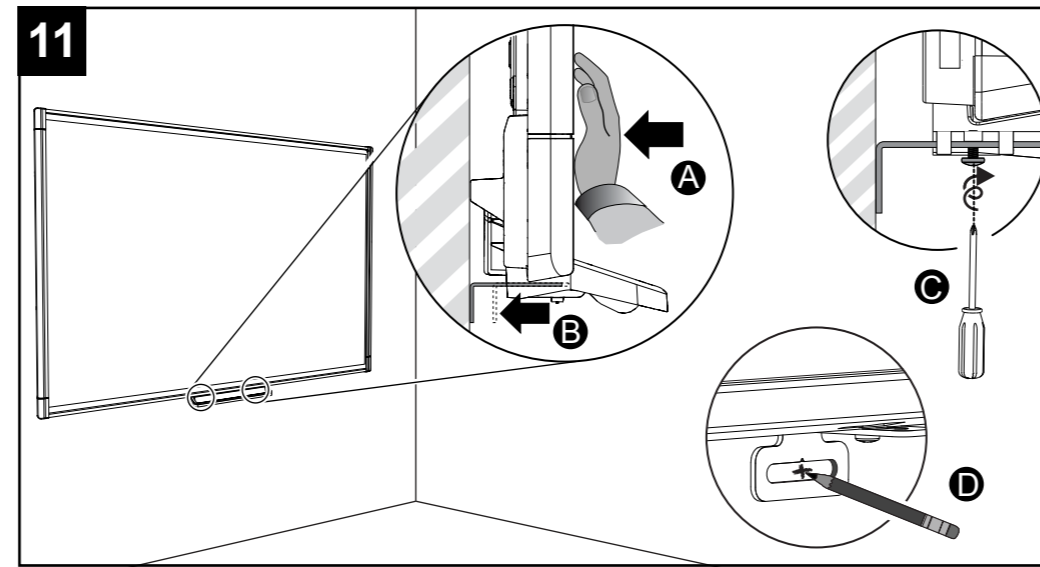
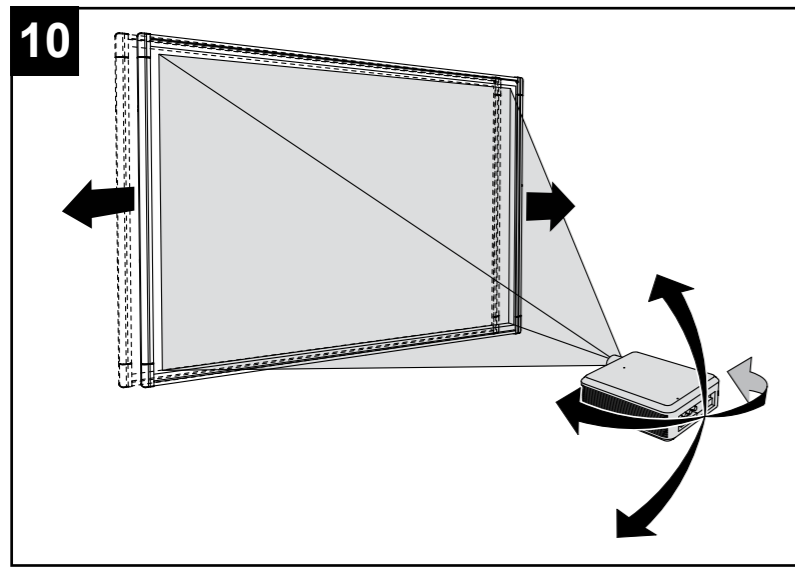

**Hardware environmental compliance**

SMART Technologies supports global efforts to ensure that electronic equipment is manufactured, sold and disposed of in a safe and environmentally friendly manner.

 **Waste Electrical and Electronic Equipment and Battery regulations (WEEE and Battery Directives)**  
 Electrical and electronic equipment and batteries contain substances that can be harmful to the environment and to human health.  
 The crossed-out wheeled bin symbol indicates that products should be disposed of in the appropriate recycling stream and not as regular waste.

See [smarttech.com/compliance](http://smarttech.com/compliance) for more information.

[smarttech.com/support](http://smarttech.com/support)  
[smarttech.com/contactsupport](http://smarttech.com/contactsupport)

